

ENGINEERING DRAWING

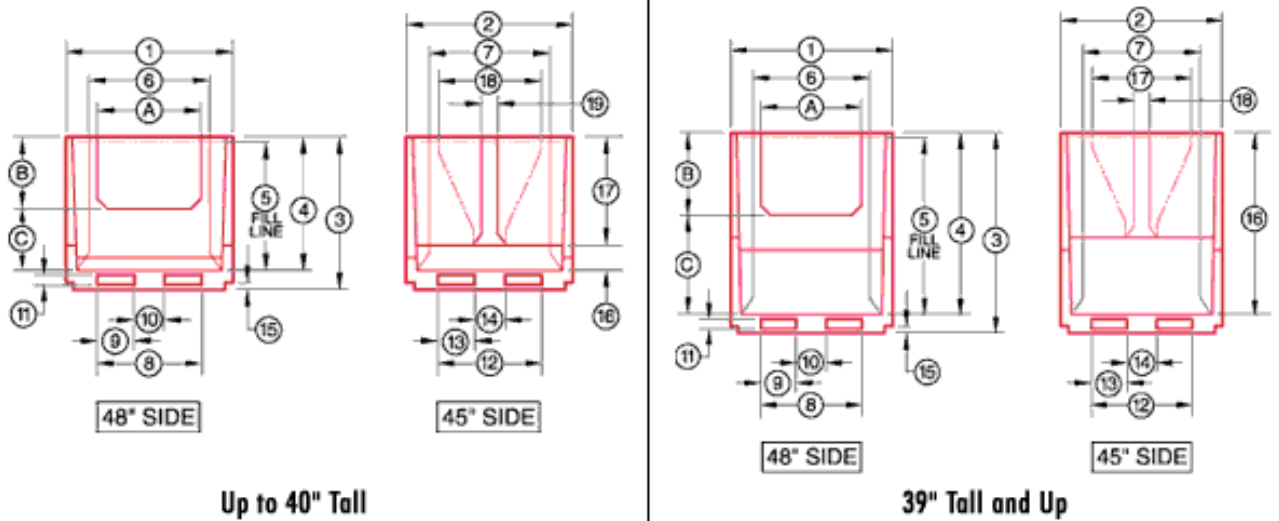

4548 Engineering Drawing

Container	4525	45338 ¹	4534	4539	4542	4548	4550
External Dimensions							
1	48	48	48	48	48	48	48
2	45	45	45	45	45	45	45
3	25	33	34	39	42	48	50
Internal Dimensions							
4	19.4	27.5	28.4	33.3	36.6	42.5	44.5
5	18.6	26.6	27.5	32.3	35.4	41.5	43.3
6	44	44	44	44	44	44	44
7	41.5	41.5	41.5	41.5	41.5	41.5	41.5
Fork Tunnel Dimensions							
8	34.3	34.3	34.3	34.3	34.3	34.3	34.3
9	10.4	10.4	10.4	10.4	10.4	10.4	10.4
10	13.5	13.5	13.5	13.5	13.5	13.5	13.5
11	3.6	3.6	3.6	3.6	3.6	3.6	3.6
12	27.6	27.6	27.6	27.6	27.6	27.6	27.6
13	9.8	9.8	9.8	9.8	9.8	9.8	9.8
14	8.0	8.0	8.0	8.0	8.0	8.0	8.0
Stack Interlock							
15	0.8	0.8	0.8	0.8	0.8	0.8	0.8
Sidewall Height							
16	7.5	15.5	7.5	19.5	28.5	28.5	28.5
17	12	12	21	N/A	26	26	26
Sidewall Opening							
18	N/A	N/A	26	N/A	9.9	9.9	9.9
19	N/A	N/A	9.9				
Drop Door Dimensions							
A	33	33	32.9	33	33	33	33
B	11.9	11.9	16.1	11.9	20.9	20.9	20.9
C	7.1	15.1	11.6	21.2	15.1	21.1	23.2

(Units in inches)

¹Dunnage model. All dimensions and specifications are approximate. Interior height dimensions measured from center; variances may result due to center crown. Tare weight is based on the 2-drop-door black model, and will vary based on color and configuration.

Materials and workmanship guaranteed for 3 years. Material: HDPE